

# The Huida HD580 UAV

## Base Use — V1.0



抖音号「惠达科技」



公众号「惠达全程机械化平台」



视频号「惠达兄弟」



快手号「惠达兄弟」

## personnel



1. UAV operators shall have the UAV operation qualification recognized by Huida Technology;
2. Healthy health, non-drinking state, no disease state, etc

## equipment



1. Confirm whether the weather conditions meet the operation requirements, such as wind speed, ambient temperature, weather conditions, etc.;
2. Confirm the wind direction to avoid the drug damage received by non-similar crops in the lower air outlet;
3. Confirm whether there are interference sources in the operation area;
4. Confirm whether the operation area is a no-fly area

## environment



1. Ensure that all parts of the UAV are intact;
2. Ensure that the external battery of uav intelligent battery and remote control is sufficient;
3. Confirm the rocker mode

# Planning plot

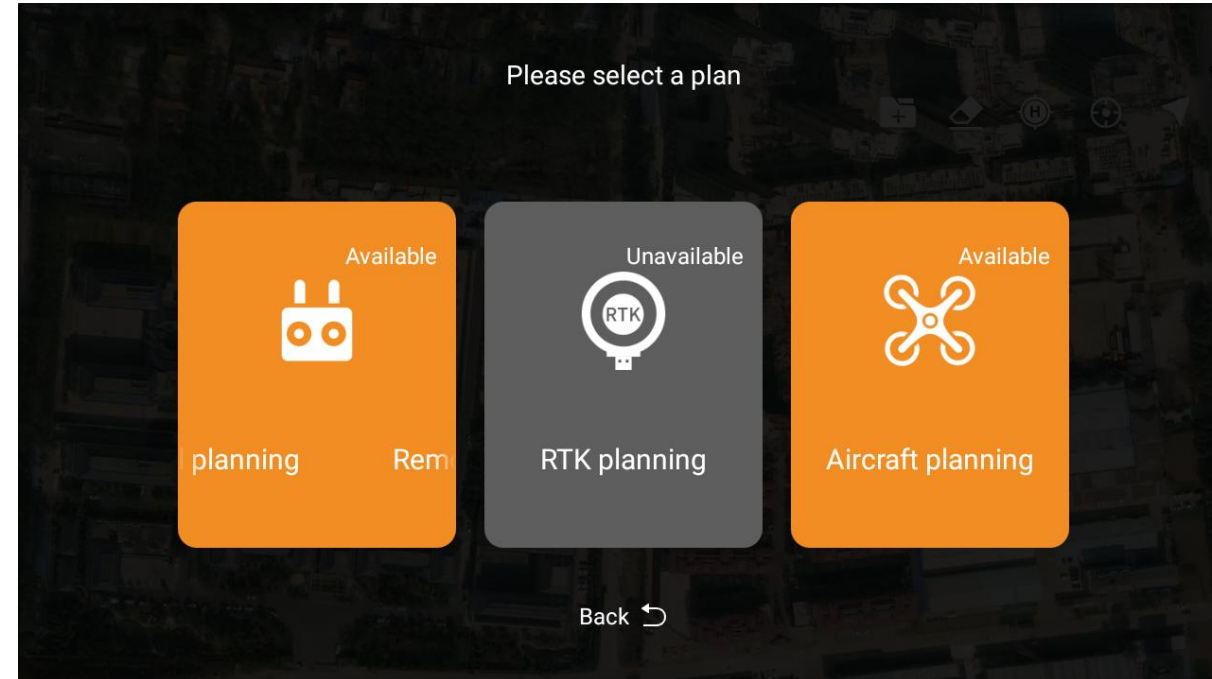

## Click on the planning plot

## Select the appropriate planning method

Planning plot method	accuracy	remarks
RTK planning	tall	The most ideal way of planning the plot can accurately determine the plot boundary points and obstacles.
Aircraft planning	tall	Need good flying skills, need to cooperate with the camera to complete the planning plot.
Remote control planning	low	The boundary points and obstacles need to be determined around the plot.
Map planning	low	According to the map display and the actual plot, boundary points are added to the map. It is suggested that the map planning is applicable in the case of the plot rules, no obstacles in the plot, and no obstacles around the plot.

# Planning plot



In the plot planning, the corresponding planning is carried out according to the site

order number	name	Functional items
1	boundary point	The boundary points are added to all the inflection points to complete the plot boundary planning
2	Round obstacles	There are circular obstacles in the plot, and the radius size can be adjusted
3	Polygon obstructions	With irregular shaped obstacles in the plot, multiple obstacle points can be set according to the obstacle shape
4	reference point	A reference point can be added outside the planned plot to facilitate the correction of the latest aircraft RTK positioning as the benchmark
5	Round-type non-work area	If the round plots in the plot are not sown or sprayed, this planning shall be conducted
6	Polygons are non-job areas	Plan for plots without polygons, seeding or spraying
7	guide	In the case of people not losing the land, the horizontal and vertical auxiliary line can be planned through outside the plot, and the intersection point of the auxiliary line is the position of the obstacle
8	label	Record the location in the plot to be marked according to the requirements (for RTK planning mode only)

# Edit plots-Airpoint editing

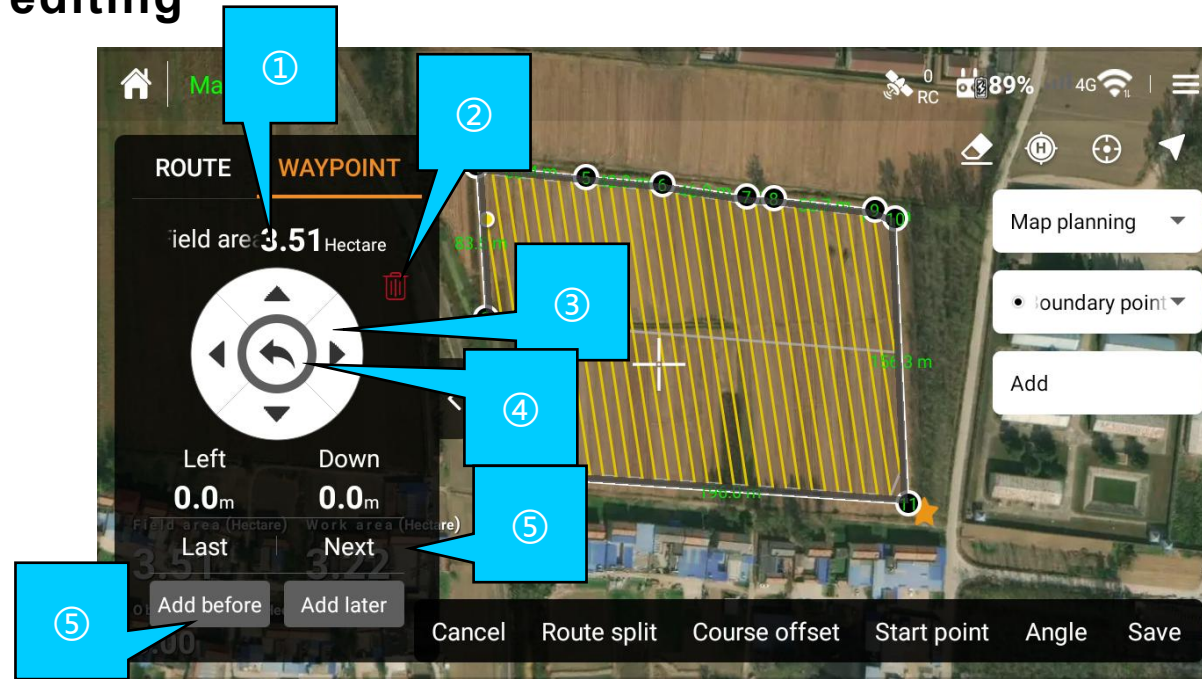

order number	name	Functional items
1	Plot area	The area of the planned plot
2	Away point delete	The key is removed from the navigation point
3	Airpoint fine-tuning	You can click the navigation point to be adjusted to fine-tune up, down, left and right, at 0.5m per time
4	cancel	Navigation point fine-tuning error, you can press the cancel button
5	Navigation point selection	If you have clicked point 3, click the last to point 2, click the next to point 4
6	The boundary points are added	Before or behind the selected boundary point, as at the location of the selected planning method (remote control / map / RTK / UAV) (described for optimization)

# Edit plot-route editor

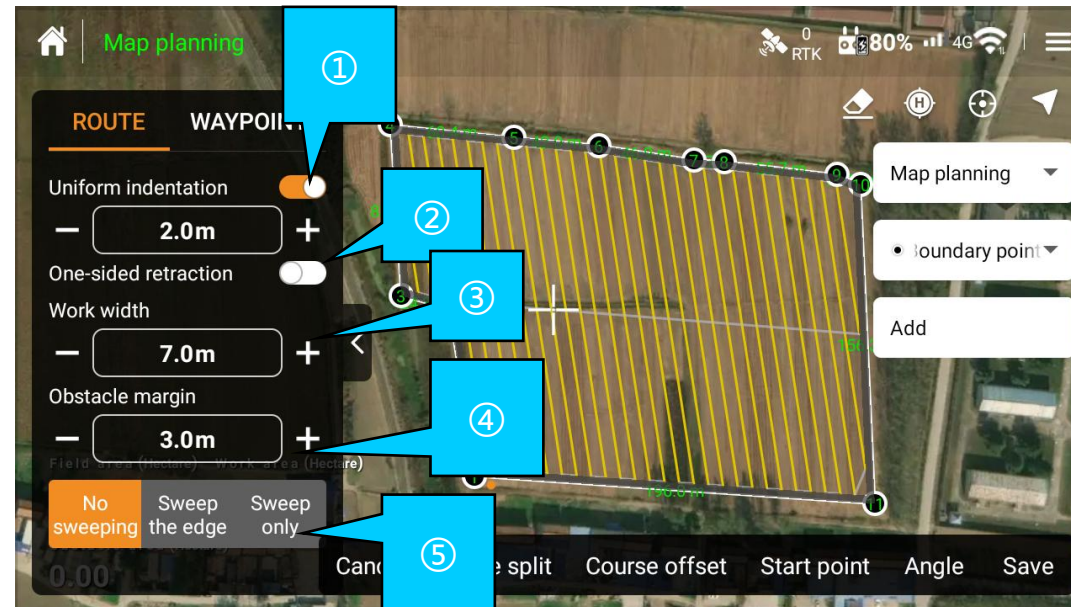

order number	name	Functional items
1	Intracement distance regulation	Retraction distance
2	Unilateral retraction switch	When the unilateral internal switch is turned on, only for the selected boundary line, and when the unilateral internal switch is turned off, all boundaries are unified
3	Homework spacing	Operation spacing adjustment
4	obstacle spacing	Adjust the distance between the obstacle boundary and its corresponding air route
5	Side sweep function setting	The edge scanning function setting, can choose not to sweep the edge, only after the completion of the block operation scanning edges, and can set the edge scanning direction, clockwise or counterclockwise operations

# Edit Plot-route segmentation

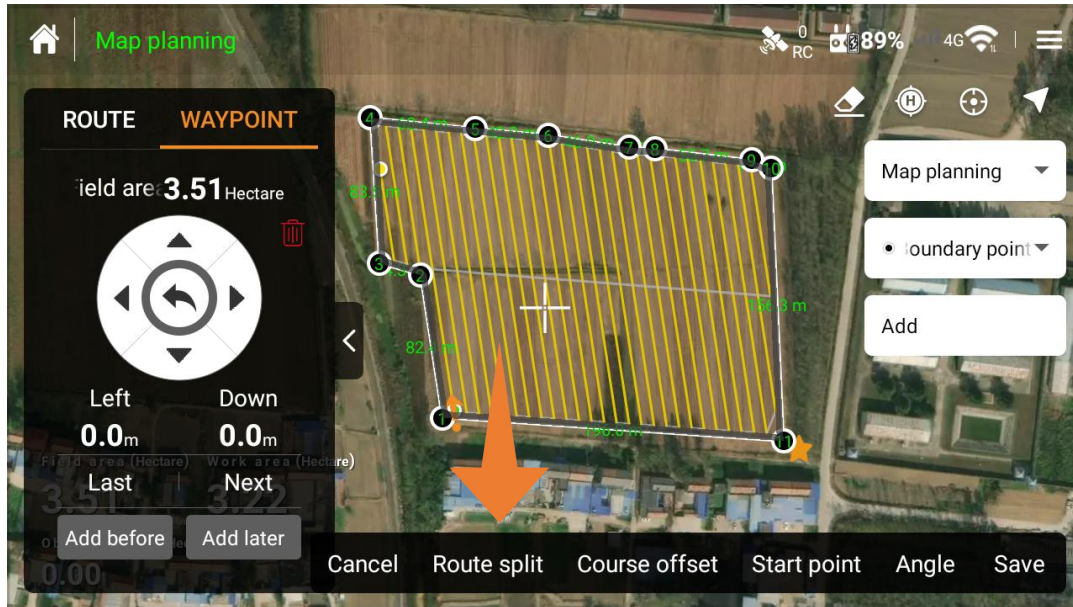

Route segmentation is to divide routes according to the percentage of routes, supporting dividing routes from left to right and from right to left. The segmented routes are not shown, and the retained routes are shown in yellow



***pay attention to:***

**Route segmentation is based on the percentage of the number of routes, not based on the percentage of the plot area**

# Edit plot-route offset

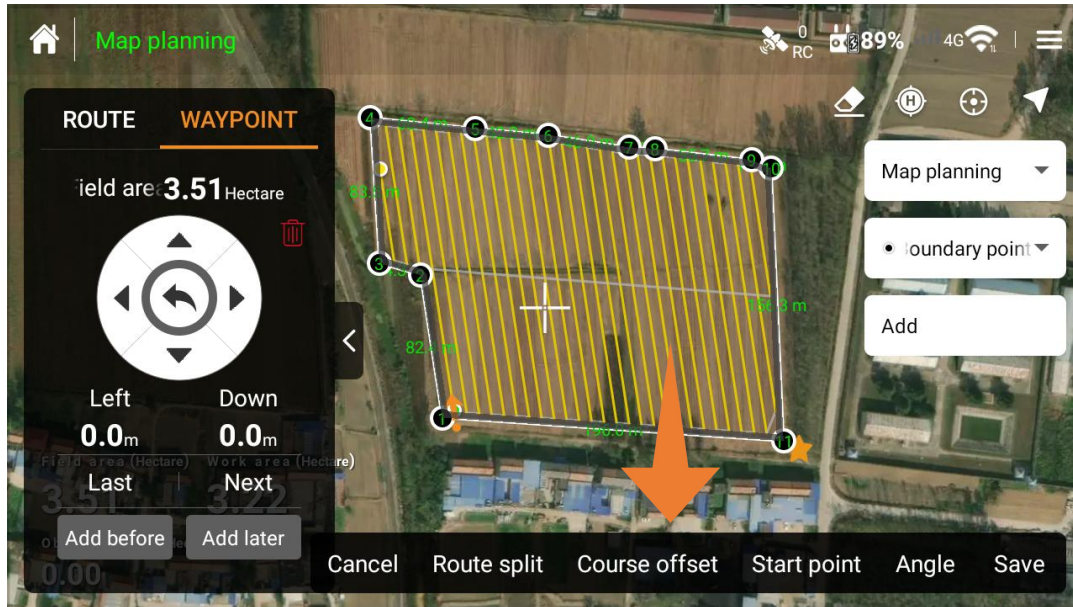

According to the set reference point, place the UAV or the remote control at the reference point, select and correct it to the UAV and the remote control position, and click OK

# Edit plot-start point edit

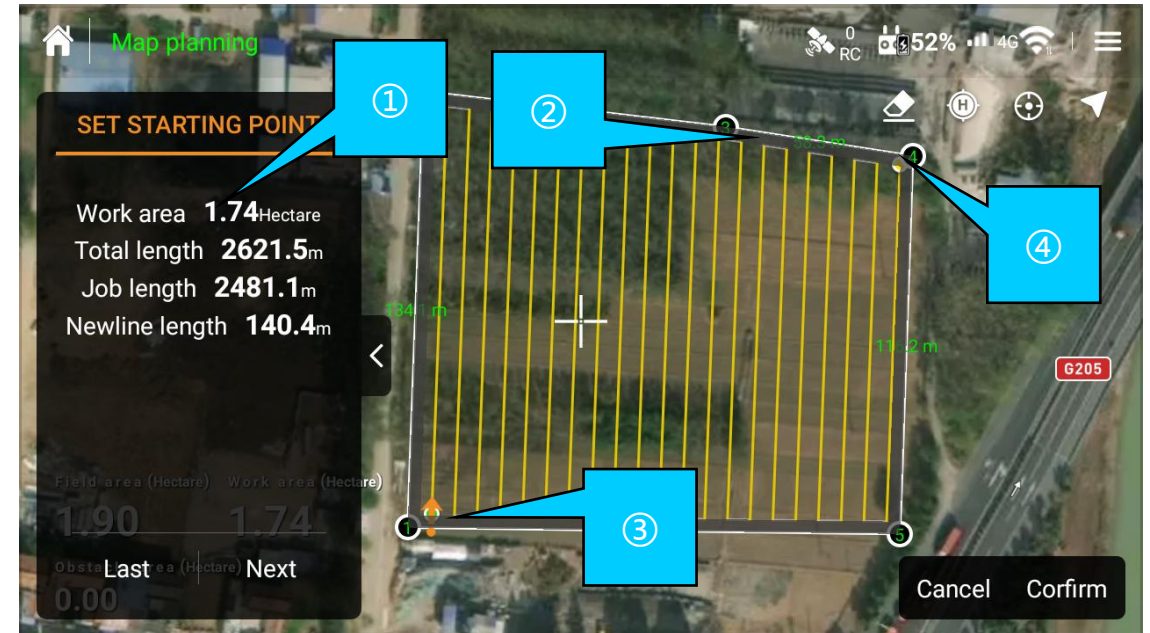
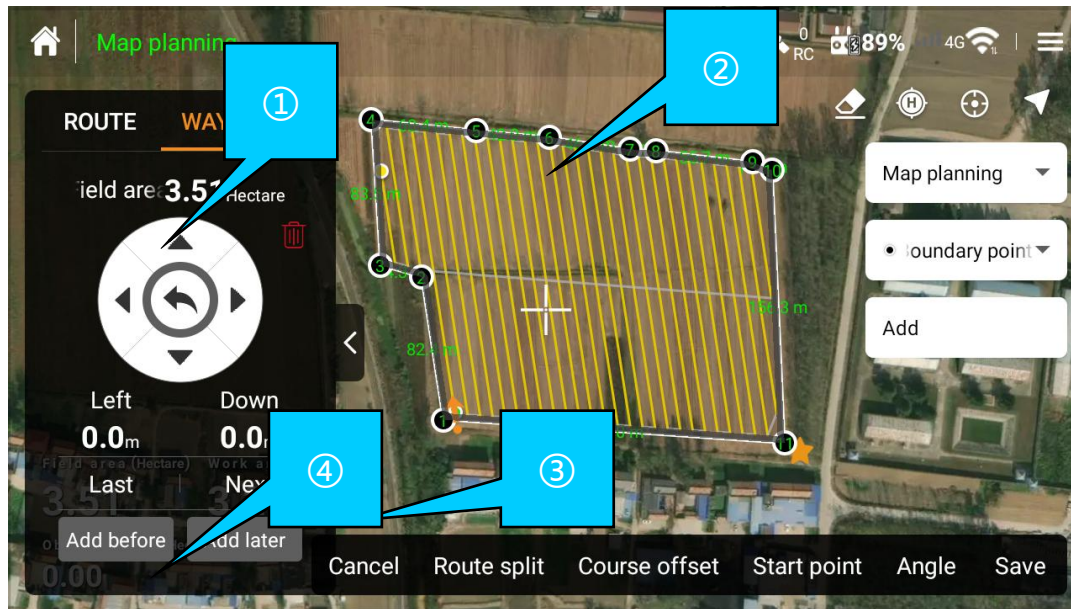

order number	name	Functional items
1	Plot information	According to the planned plot, the system automatically calculates the operation area, total length, operation length and line change length
2	Start point planning	By clicking on the different boundary lines, the route is in the same direction as the clicked boundary line
3	Orange arrow	The orange arrow indicates the UAV starting operation point
4	Navigation point selection	The starting point can be adjusted according to the location of the navigation point. For the clicked navigation point, if you click the 2nd navigation point, the last point will be adjusted to the navigation point 1, and the next point will be adjusted to the navigation point 3

# Edit plots-heading editing

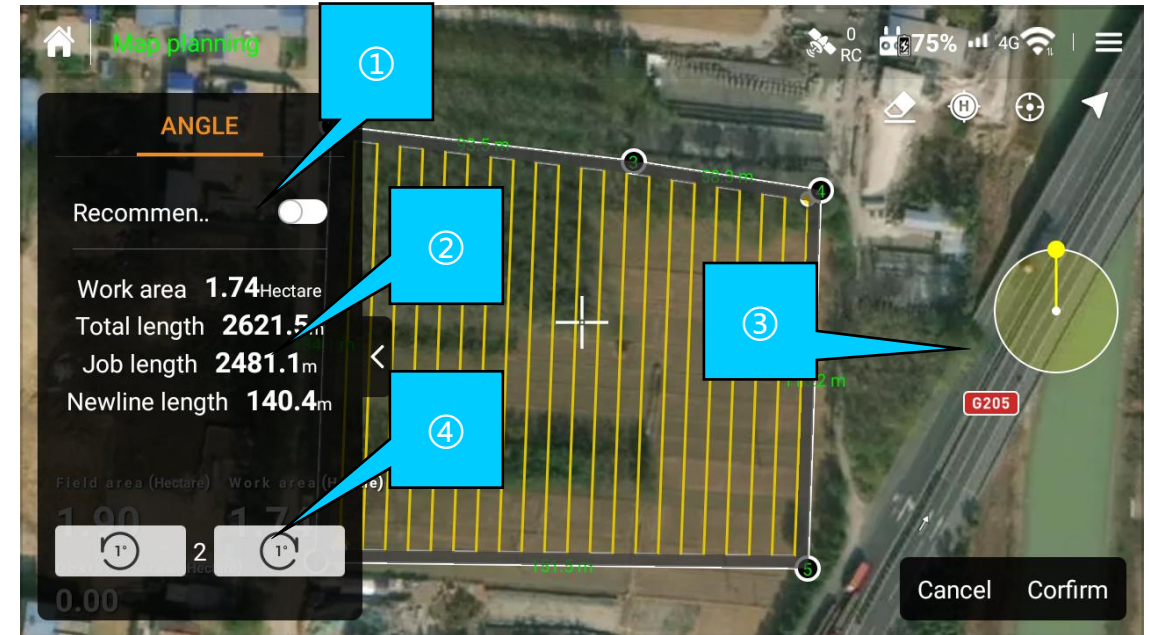
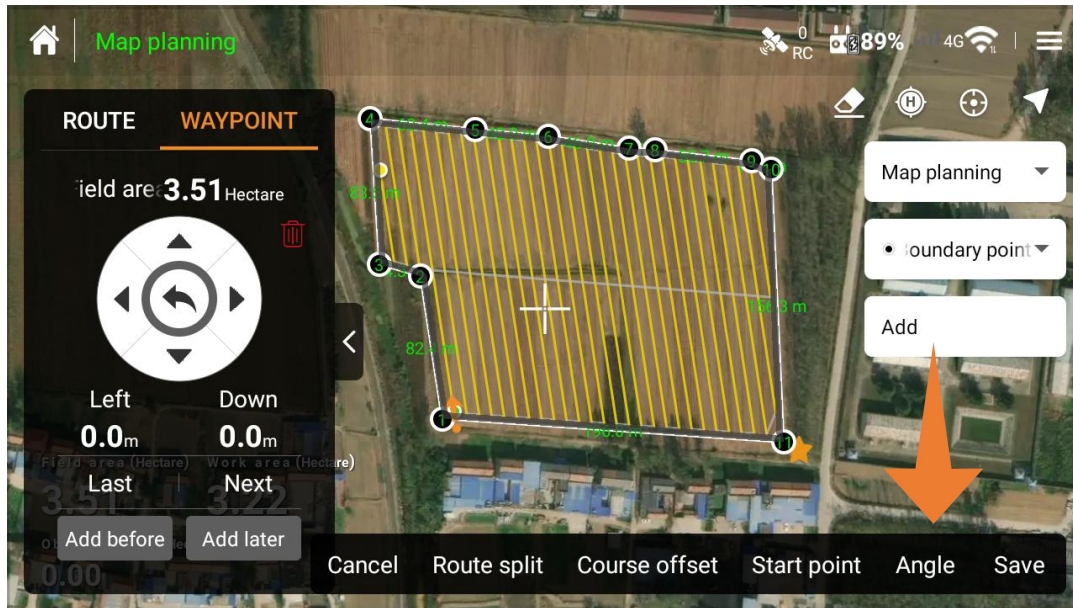

order number	name	Functional items
1	Recommended heading	Intelligent generate route direction according to the planned plots
2	Plot information	According to the planned plot, the system automatically calculates the operation area, total length, operation length and line change length
3	Route gyroscope	Drag the route adjustment gyro button to generate the required route direction
4	Route Angle adjustment	The course can be adjusted according to the counterclockwise and clockwise angle, adjusting the angle to 1° per point

# Edit the parcel-the parcel save

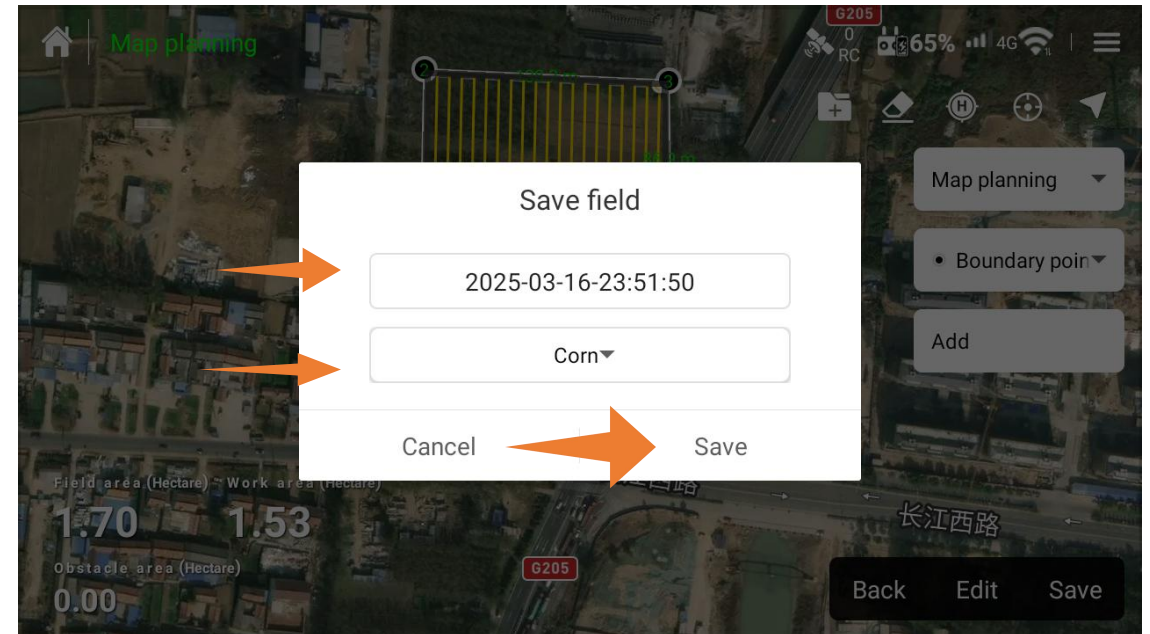
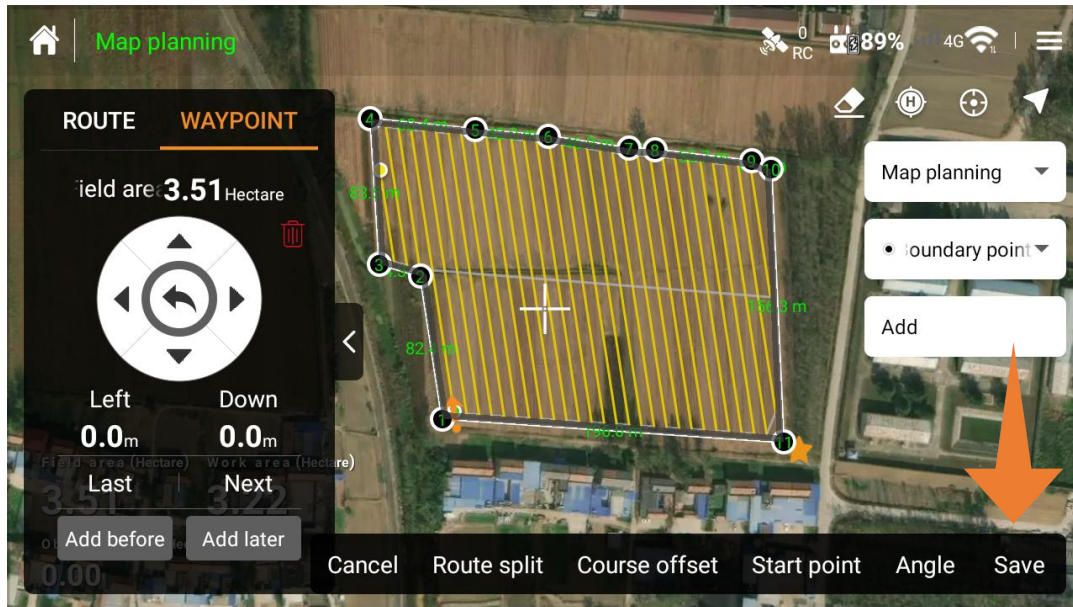

Click Save the edited plot, enter the plot name according to the requirements, select the crop type of the operation, and click Save again

# Call the plot

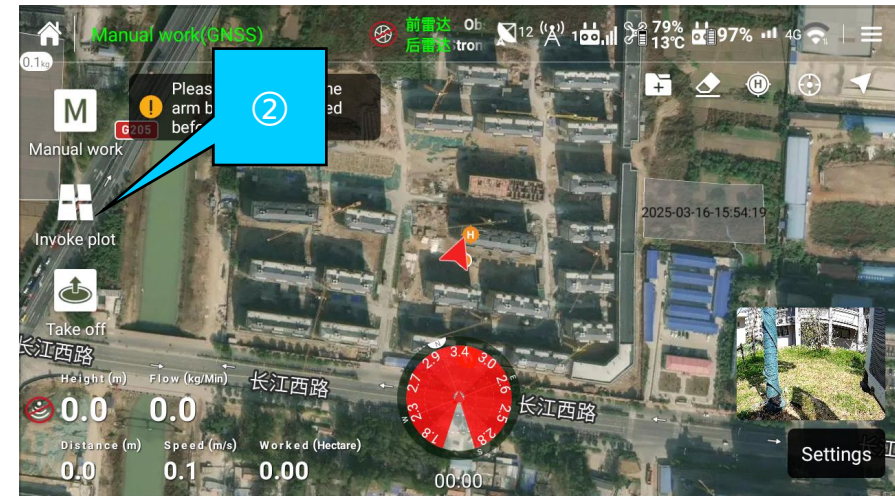

How to call the plot		
order number	way	Functional items
1	Way a	Save the finished plot and directly click on the Call
2	Method 2	You can also click the call plot on the (start job) page to find the information of the historical job plot and select as required

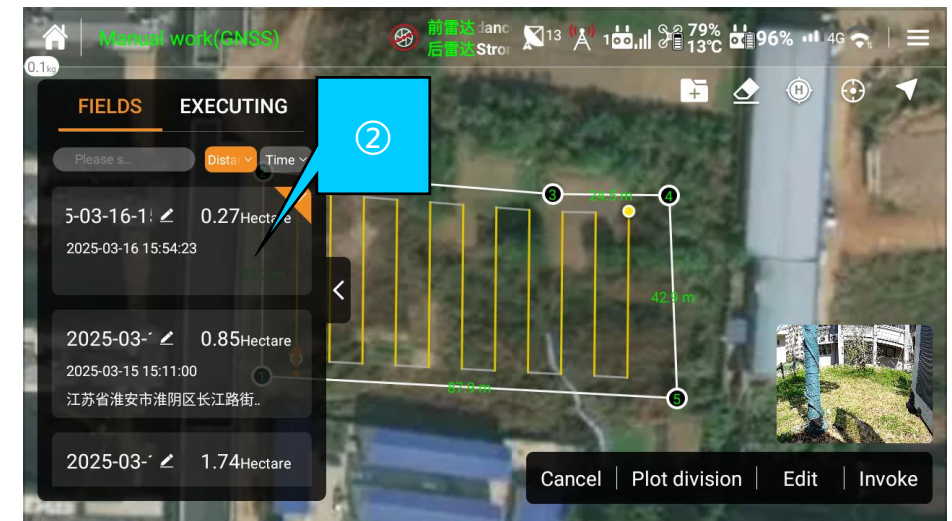

# Spray operation Settings

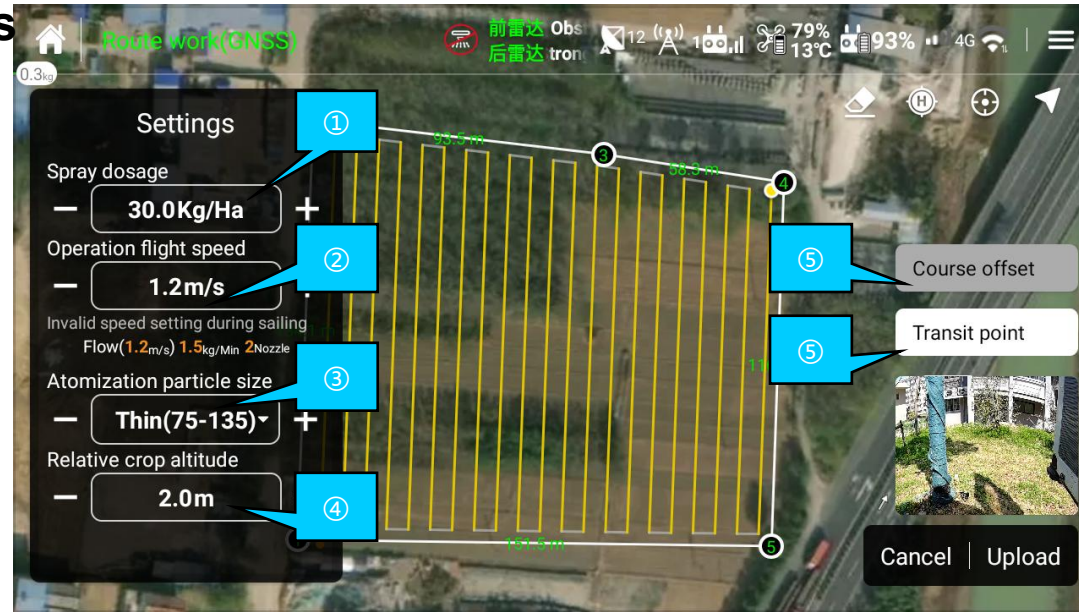

order number	name	Functional items
1	Spray dosage	Operation spraying dosage adjustment
2	Operation flight speed	Speed adjustment per second of the operation flight
3	Fog granularity	Spray atomized particle size selection, very thick / thick / medium / fine / slip
4	Relative crop height	Flight titudes relative to crops during drone operations
5	Route offset	Route offset function
6	intermediate transit point	At the departure point, the UAV can set a transit point to the operation point or on the return point. The UAV will fly to the next transit point or the operation and sailing point, and two transit points can be set in the three plots outside the plot

# Upload and execute the job

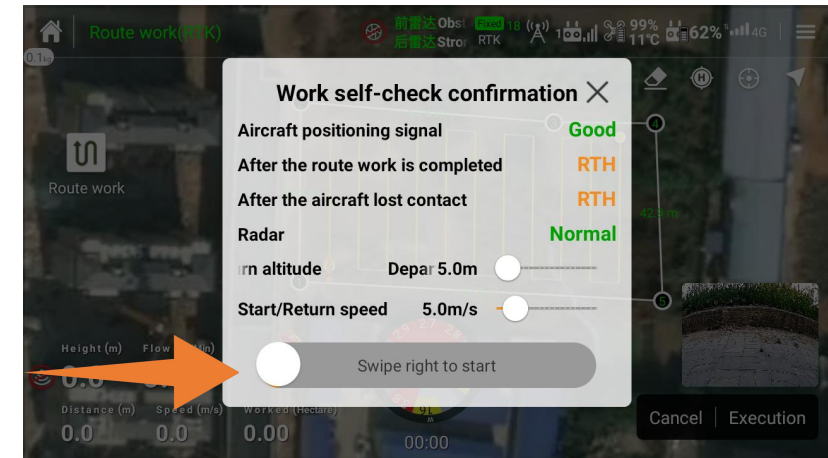
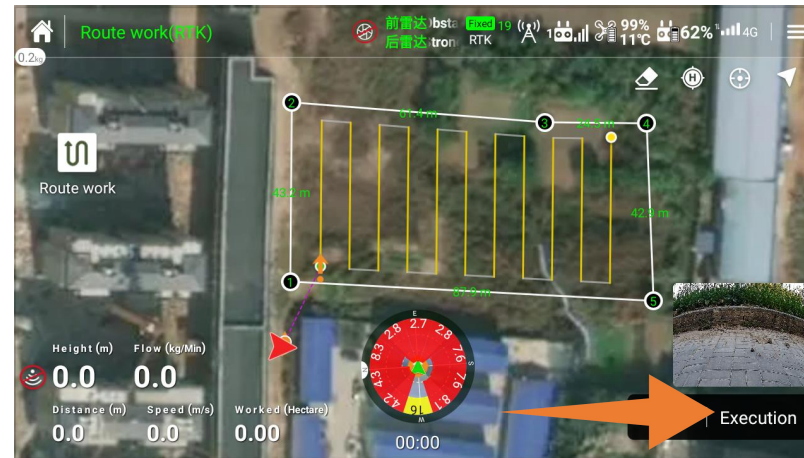

The set operation parameters will be uploaded, and click the execution after the upload, there will be the operation self-check confirmation, check whether it is normal, slide the white button to the right side without objection, and then the UAV will work independently according to the planning setting of the block

# manual working

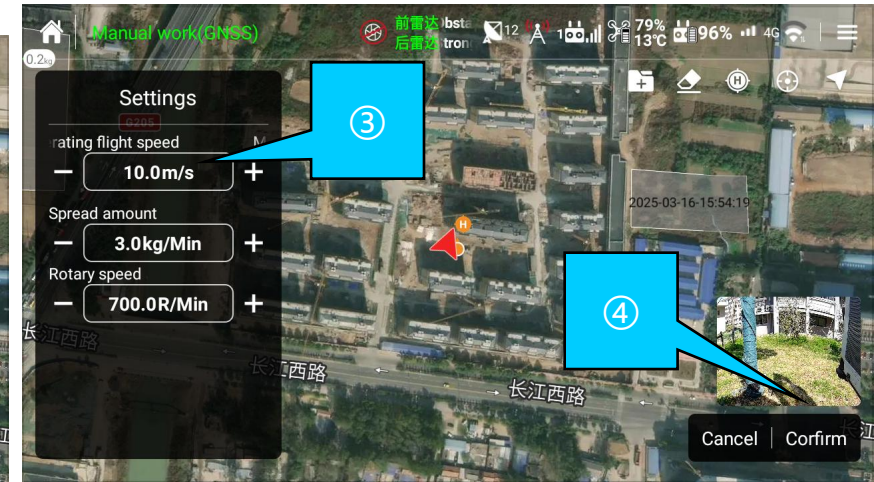
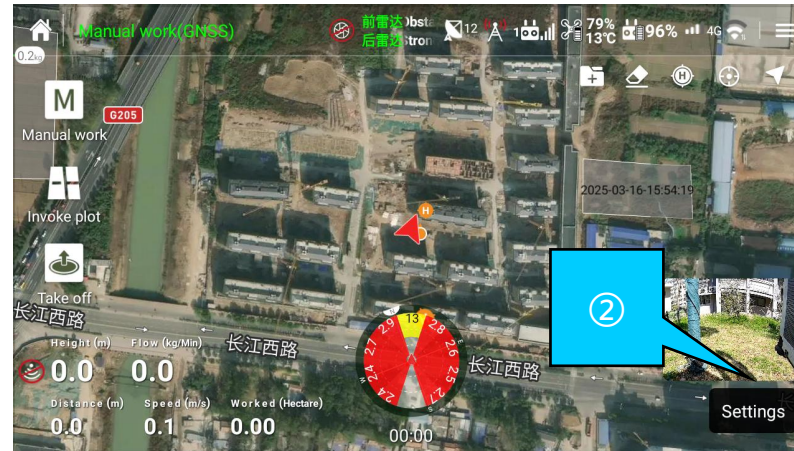
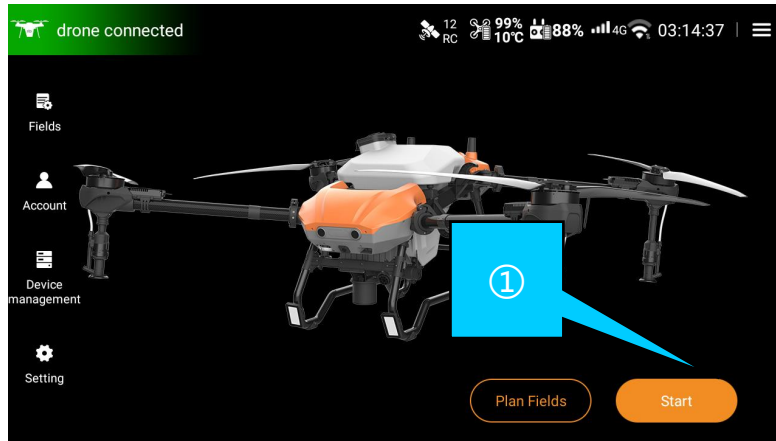

order number	name	Functional items
1	Start your homework	Home page click to start the job, the default is the manual job mode
2	Job Settings	Set operation parameters, set spraying amount according to requirements, degree of atomized particles, extremely thick / coarse / medium / fine / slip
3	Route gyroscope	Drag the route adjustment gyro button to generate the required route direction
4	Start manual work	Click OK to start the manual job

# Manual work- -Enhanced manual work

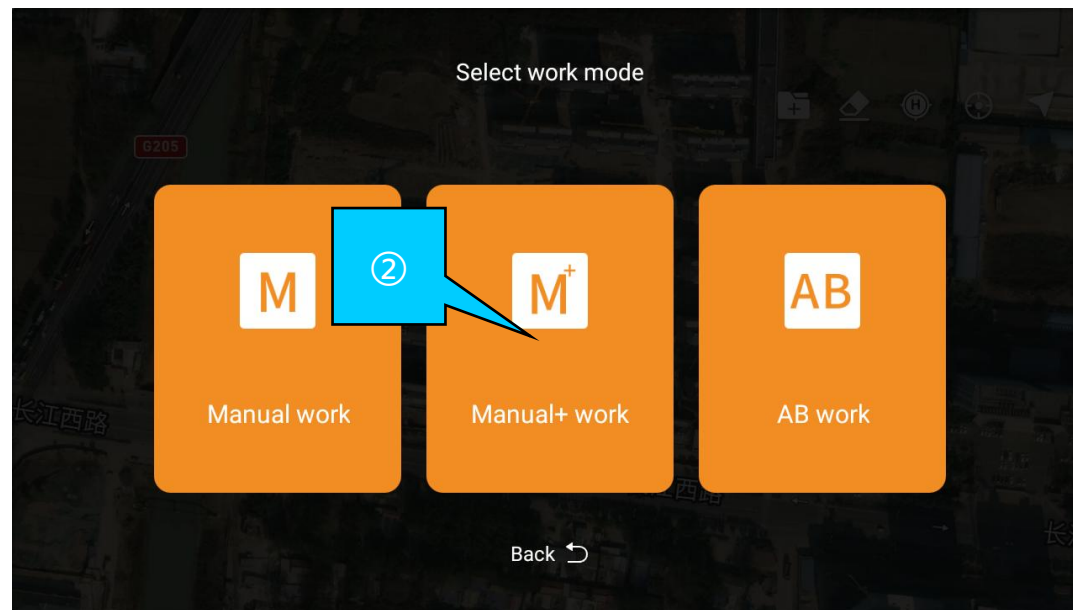
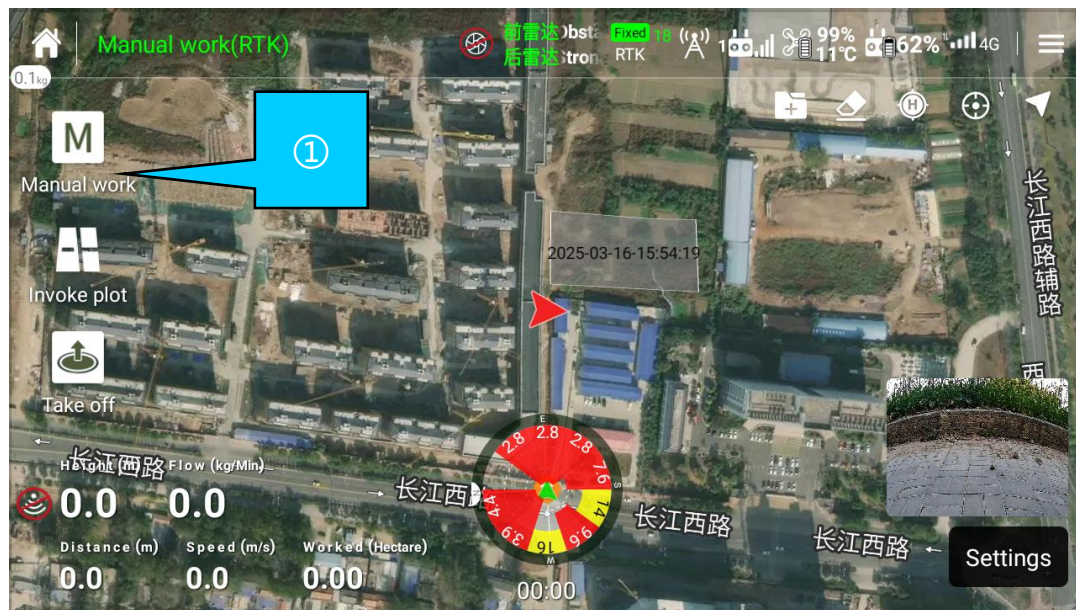

order number	name	Functional items
1	manual working	Manual Job page, click on Manual Job
2	Enhance manual work	Select the Enhanced manual job

# Manual Jobs- -Enhanced manual work

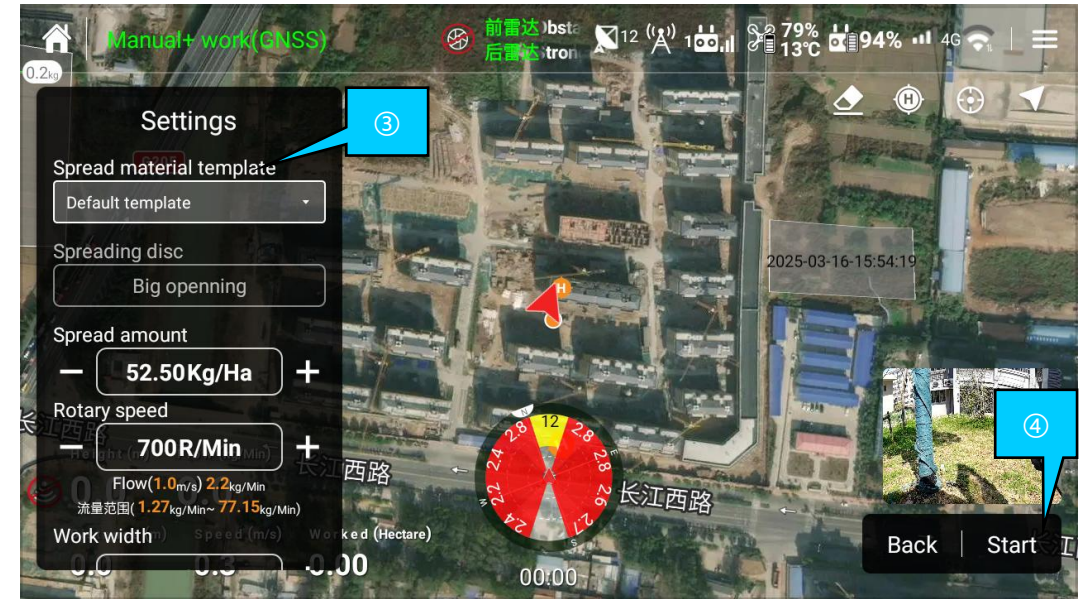

order number	name	Functional items
3	Enhanced the manual job settings	Set up the seeding or spraying operation parameters
4	Start the button	Click on the start button
5	Adjust the heading for the manual operation	According to the requirements of the site plot, the course of the UAV will be adjusted manually, and the manual operation will fly in a straight line according to the adjusted course
6	Left offset line change	To the end of the plot, click left or right for line flight
7	End of homework	After the end of the operation, click the end button to complete the plot modification operation

# Manual work- -AB straight-line work



1. Click on the manual operation button

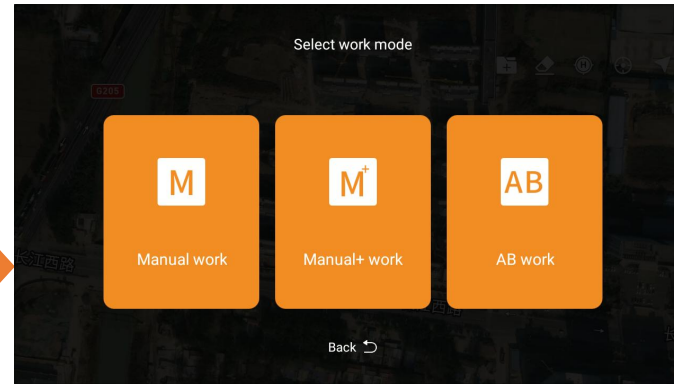

2. Select the AB job

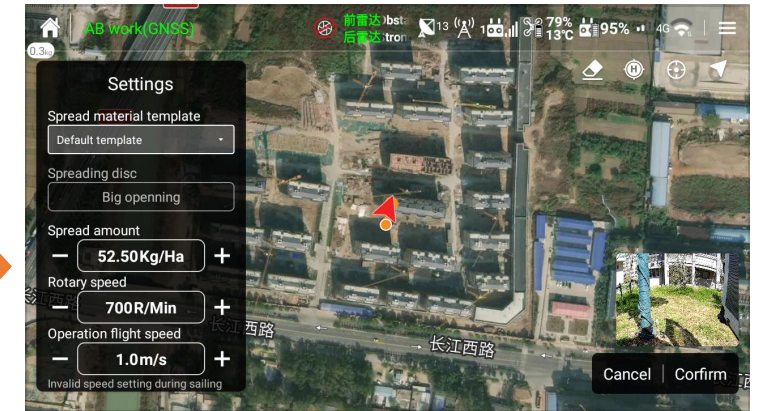

3. Set the job parameters



6. Set the job parameters and upload the plots



5. Add the point of B



4. Add point A and fly to point B

# Manual work- -AB straight-line work

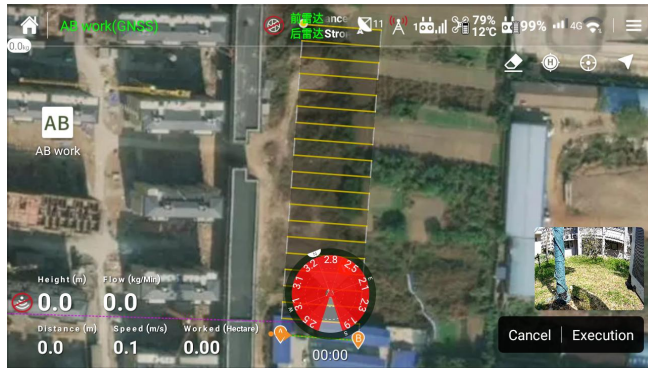

7. Click on the execution button

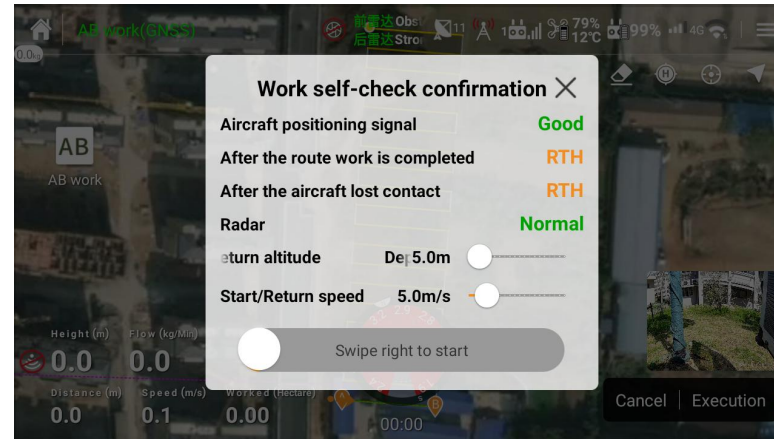

8. Slide the button to perform the job

## Precautions for using the remote control



*pay attention to:*

- 1. When working, please install external batteries to ensure that the power is sufficient;**
- 2, the antenna must be expanded: if the antenna is not expanded, the transmission effect and transm**
- 3. The antenna should not point to the UAV: the signal at the top and bottom of the antenna is the w**

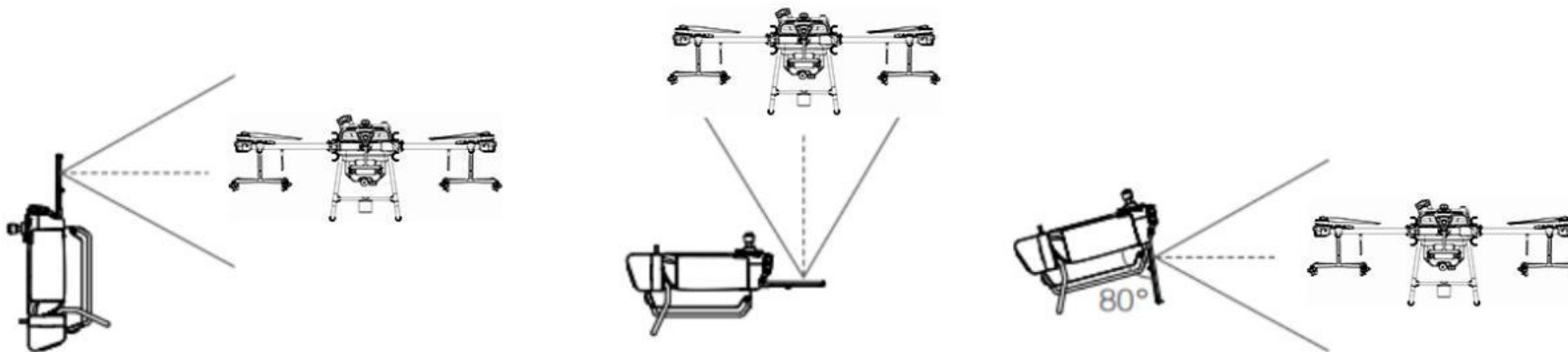

# THANK S



sales@huidatech.cn  
<https://www.huidaagtech.com/>



抖音号「惠达科技」



公众号「惠达全程机械化平台」



视频号「惠达兄弟」



快手号「惠达兄弟」