

**Agricultural Drone Instruction Manual**

# **HD580 Agricultural Drone Safety Operation Manual**

Version 1.0

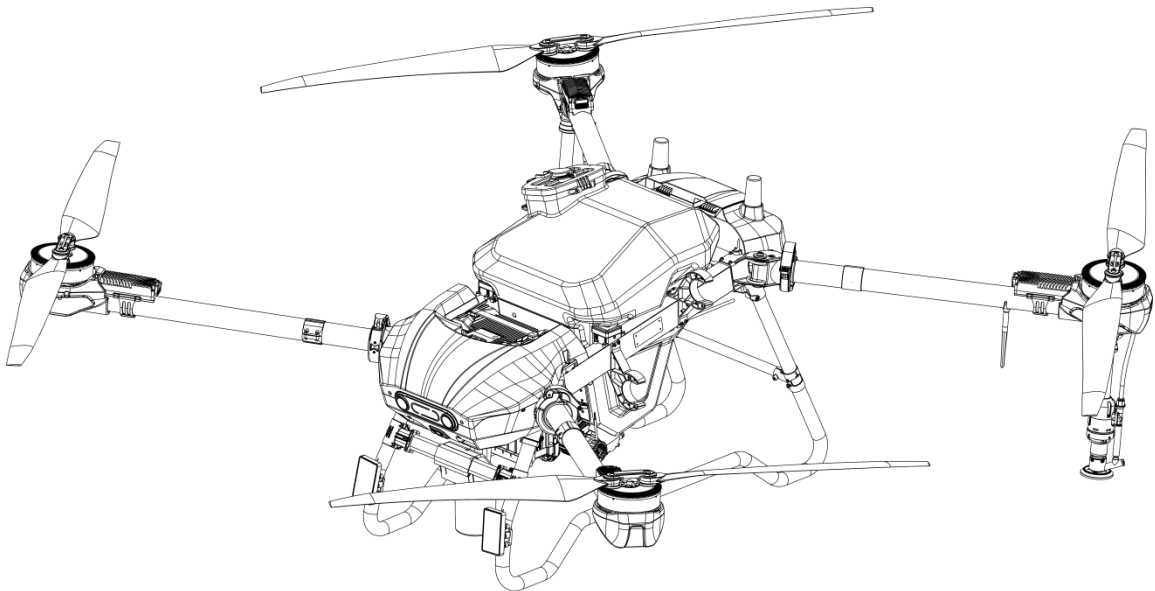

## Battery Safety Precautions

1. If the smart battery is observed to be bulging, leaking, deformed, or showing visible damage, stop use immediately and contact Huida Technology's authorized dealers or service centers for assistance.
2. Do not transport smart batteries that exhibit potential safety hazards, including bulging, leaking, or visible damage.
3. Do not charge the smart battery in a wet state.
4. When the drone is powered on, do not plug or unplug the smart battery to avoid connector damage.
5. Treat the smart battery with care - hold and place it gently and never attempt to disassemble it privately.
6. Store the battery, drone, remote control, charger and other equipment in a dry environment with a temperature of 10 °C -30 °C . Avoid storing these items in locations prone to water leaks or high humidity.
7. When storing batteries, it is critical to avoid stacking them.

## Transportation Safety Precautions

1. Transport vehicles must have a separate rear cargo compartment (as shown in the figure) to ensure separation of personnel and the drone; otherwise, if not separated, personnel inside the vehicle may inhale pesticides and risk poisoning.
2. Keep vehicle windows open as much as possible to maintain good ventilation.
3. Absolutely do not close the windows and turn on the air conditioner' s internal circulation, as this greatly increases the risk of pesticide inhalation and poisoning.
4. Before loading, the drone' s spraying system must be thoroughly rinsed with clean water.
5. After loading, secure the drone firmly to prevent damage during sudden braking or sharp turns of the transport vehicle.
6. Before transportation, ensure that the drone and smart battery are separated.
7. It is recommended to transport batteries using the original manufacturer' s battery packaging.
8. When transporting the drone, fold the arms and propellers, and secure the propellers with propeller holders. Use safety belts to fix the drone frame, ensuring

the drone remains stable during transportation.

9. Operate the transport vehicle strictly in accordance with the safety regulations set by the traffic management authorities.
10. Driving under the influence of alcohol, drunk driving, and fatigued driving are strictly prohibited.



## **Emergency Propeller Stop**

1. Do not stop the motor during flight, otherwise the drone will crash. Unless a special situation occurs (e.g. the drone may crash into a crowd), where an emergency stop of the motors is required to minimize injuries.
2. Emergency propeller stop: When holding the left and right joysticks outward for more than 0.5 seconds, the motor will unconditionally power off and come to a stop, and at this point, the drone will fall.

## **Flight Restriction and Laws and Regulations**

1. Please consult Huida Technology for detailed data on flight restrictions and flight bans, or consult the local air traffic control department to comply with local laws and regulations. If necessary, users need to apply for authorisation to use the drone from the relevant authorities.
2. All Huida agricultural drones in China are controlled to fly at an altitude of 30 m and below, please consult local laws and regulations if you are not in China.
3. All Huida agricultural drones in China are controlled to fly within a radius of 2,000 m, please consult the relevant local laws and regulations if you are not in China.
4. When using the Huida agricultural drone in non-China regions, please strictly

comply with the laws and regulations of your respective country.

## Geo-fencing

1. The geo-fencing feature of Huida agricultural drones is enabled by default. It restricts the drone's maximum flight altitude, speed, and distance.
2. In the Huida Drone App, users can configure safety limits for flight altitude and maximum flight distance (measured as the radius from the remote control).

## No-Fly Zones

1. In accordance with regulations set by the International Civil Aviation Organization (ICAO) and national air traffic control authorities regarding airspace management and drone operations, drones must operate within designated airspace. For flight safety, flight restriction features—including no-fly zones and geo-fencing—are enabled by default to help users operate Huida agricultural drones safely and legally.
2. No-fly zones include both globally defined airspace restrictions (published by air traffic authorities) and user-defined custom zones. Drones are strictly prohibited from entering any type of no-fly zone.
3. When approaching the boundary of a no-fly zone, the drone will automatically decelerate and hover near the edge.
4. If the drone enters a no-fly zone without positioning (GNSS signal), it will automatically land once positioning is restored. After landing inside a no-fly zone, the drone will not be able to take off again while within the restricted area.

### **Note:**

When GNSS positioning is available, no-fly zones and altitude limits work together to restrict flight. When GNSS is unavailable, only altitude limits are enforced, and the maximum flight height will not exceed 30 meters.

## Pesticide Usage Guidelines

1. Pesticides are toxic substances. Please operate in accordance with standard pesticide safety protocols.
2. During pesticide preparation, be cautious of splashing. Prevent pesticide residue on the drone frame to avoid harm to human health.
3. Use clean water for mixing pesticides. After mixing, the solution must be filtered before being added to the agrochemical container to avoid clogging the filters. If clogging occurs during operation, stop and clean the system before resuming.
4. During application, ensure that personnel remain upwind to avoid pesticide drift that may pose health risks.
5. Always wear protective gear when handling pesticides to prevent direct contact with the skin. After spraying, wash exposed skin and clean the drone and remote controller thoroughly.
6. Pesticide effectiveness is influenced by factors such as solution concentration, spray flow rate, drone-to-crop height, wind direction and speed, temperature, and humidity. These factors should be considered comprehensively to achieve optimal results.
7. Ensure that no harm is caused to animals, plants, or the natural environment within or near the spraying area due to pesticide use.
8. Contaminating rivers and drinking water sources with pesticides is a serious legal violation.
9. Handling of leftover pesticide solution: Plan operations carefully to minimize leftover pesticide. It is recommended to spray remaining solution and rinse water onto the crops. If a large amount remains, avoid excessive spraying to prevent crop damage.
10. Do not use strong acids, strong alkalis, high-temperature liquids, or pesticides banned by national regulations.
11. Safety distance: Agricultural drones are still relatively new, often attracting onlookers during operations. Always maintain a safe distance from people. Adults should stay at least 5 meters away, and children at least 10 meters, to prevent accidents.
12. Demonstrations: For public displays or demos, choose open areas away from crowds. Use fences or safety tape to mark the demonstration zone and maintain a safe distance from spectators. Never fly the drone directly above people. In case

of collision, serious injury may occur. Drones should fly at slow speeds during demos to showcase features, and aerial tricks or fast flying for performance purposes are strictly prohibited.

13. Work area marking: Clearly mark completed areas to prevent people or animals from entering and ingesting pesticide-contaminated crops. Also, ensure accurate field identification to avoid spraying adjacent plots, which may cause crop damage and disputes.

## **Ingress Protection (IP) Rating Statement**

1. Under normal operating conditions, the drone is resistant to dust, water splashes, and corrosion. Under controlled laboratory conditions, the drone(excluding the smart battery) meets the IP65 protection rating, in accordance with the IEC 60529 standard issued by the International Electrotechnical Commission. The drone frame is splash-resistant.
2. The protective capability is not permanent and may degrade over time due to aging or wear from long-term use. Damage caused by immersion in liquid is not covered under the warranty.
3. Scenarios in which ingress protection may become compromised include:
  - a. Physical collision causing deformation at sealing areas;
  - b. Cracks or damage to sealed parts of the external shell;
  - c. Improper installation or loosening of port covers or waterproof plugs

## Drone Airframe Safety Warnings

Motor rotation direction warning sticker



Arm locks warning sticker



Agrochemical container warning sticker



## Charging warning sticker



## Safety Illustrations

### 1. Recommended Areas



+



+



+



Fly in open area

Strong GNSS signals

Visual Line of Sight (VLOS)

Fly below 30m

## 2. Areas Not Recommended



Avoid flying over or near crowds, power lines, tall buildings, airports and signal towers.

Radio transmission towers, high-voltage lines, and substations may interfere with the remote control signal and threaten flight safety. Therefore, ensure safety precautions are strictly observed during flight operations.

## 3. Prohibited Areas



DO NOT use the drone in adverse weather conditions such as heavy rain (precipitation rate exceeding 25 mm in 12 hours), fog, snow, lightning, or strong winds (wind speed of 8m/s and above).

## 4. Dangerous Behaviors

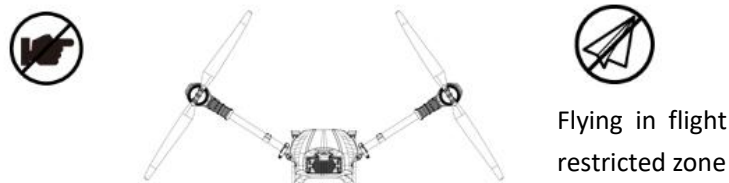

## Low Battery and Battery Drain Protection

HD580 drone is equipped with low battery alarm, battery drain alarm and low voltage alarm.

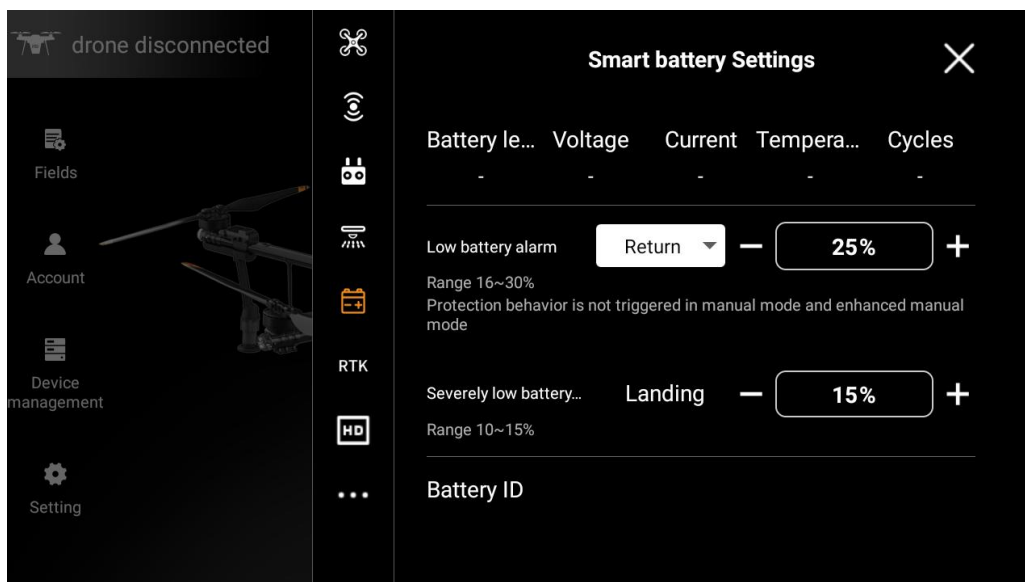

1. If the App triggers a low battery alarm, you should fly the drone to a safe area and land as soon as possible, then replace the battery. If the low battery behavior is set to Return, the drone will prompt to return automatically first once the App triggers a low battery alarm. Subsequently, it will proceed to return to its take-off point autonomously. If the low battery behavior is set to Hover, the drone will hover and await further instructions from the operator upon the App displaying a low battery alarm.

**Note:**

Operators can set the battery percentage threshold that activates the alarm in the Huida Drone App, and it is recommended to set it conservatively to ensure flight safety.

2. In the event of a critical low battery or a significant low voltage alarm, the drone will autonomously execute an emergency landing procedure, during which the operator is unable to intervene in the landing sequence.

**Note:**

Operators can set the battery percentage threshold that activates the alarm in the Huida Drone App, and it is recommended to set it conservatively to ensure flight safety.

## List of Risks and Hazards and Countermeasures

**Operation of the 3WWDZ-U70A agricultural drone carries inherent risks if not conducted in accordance with specified operational requirements, or if the drone is not operated with caution. Below are the identified risks and corresponding countermeasures:**

No.	Hazard Location	Countermeasures	Note
1	Propellers	Maintain a safe distance (more than 15 m) when the propeller is rotating.	
2	Motors	Maintain a safe distance of 0.5 m or more from a rotating motor without a propeller, and 15 m or more from a rotating motor with a propeller.	
3	Agrochemical Container	Used agrochemical containers may contain agrochemical residues, and should not be used for drinking water or grooming.	
4	Pesticides Used	Agrochemicals should be applied in accordance with the instructions for use or the guidance of an agronomist.	
5	Battery	Batteries must be operated following the prescribed usage procedures to avoid overcharging and overdischarging.	
6	Charger Use	The charger must be operated in strict accordance with the operating instructions and kept away from flammable and explosive substances during use, and fire-fighting equipment should be readily available in proximity.	
7	During Operation Flight	Flight operations in downtown areas are prohibited; During field operations, maintain a safe distance (over 15m) from crowds.	
8	During Pesticide Spraying Operations	Keep the operation area away from the farming area, at least 60m away depending on the weather conditions.	